

PL 4 - AC Motors - Main components

Objectives: Identification of the main components and demonstration of the working principle of induction (AC) motors (three phases and one phase). Characteristic curves (ex. Torque-speed). Three phases balanced electrical power, star (Y) and delta ( $\Delta$ ) connections.

Documents available

PL classes: 1) Catalogue carpanelli-M71b4.pdf

Web sites: [www.carpanelli.net](http://www.carpanelli.net)  
[www.marellimotori.com](http://www.marellimotori.com)

1. Identification of the main components of AC motors: fill in the following figures the designation of the respective component.

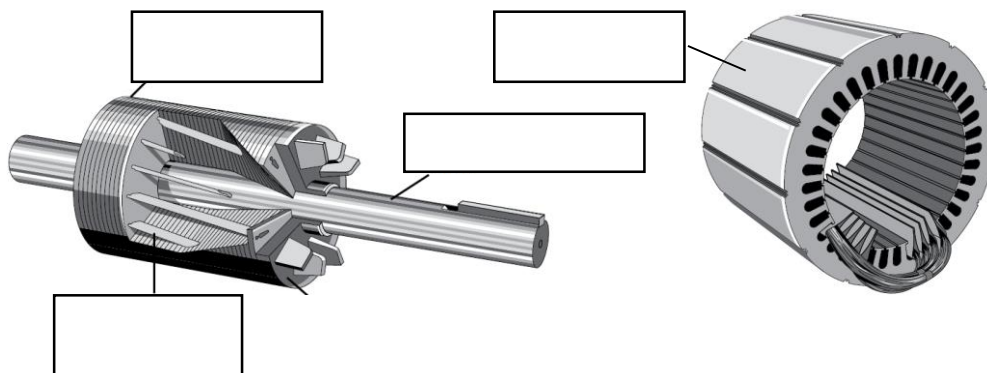
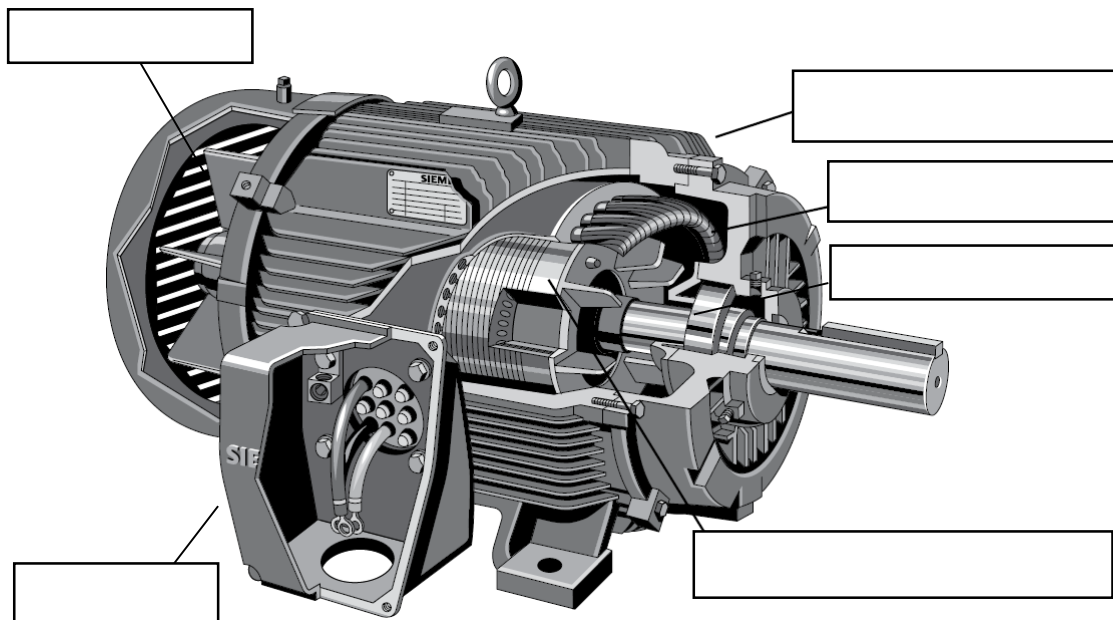

PL 4 - AC Motors - Main components

2. Characteristic curves Torque-speed ( $T, \omega$ )

- a. Identify in the graph below the following ( $T, \omega$ ) working points: nominal, starting, maximum torque and synchronous speed.

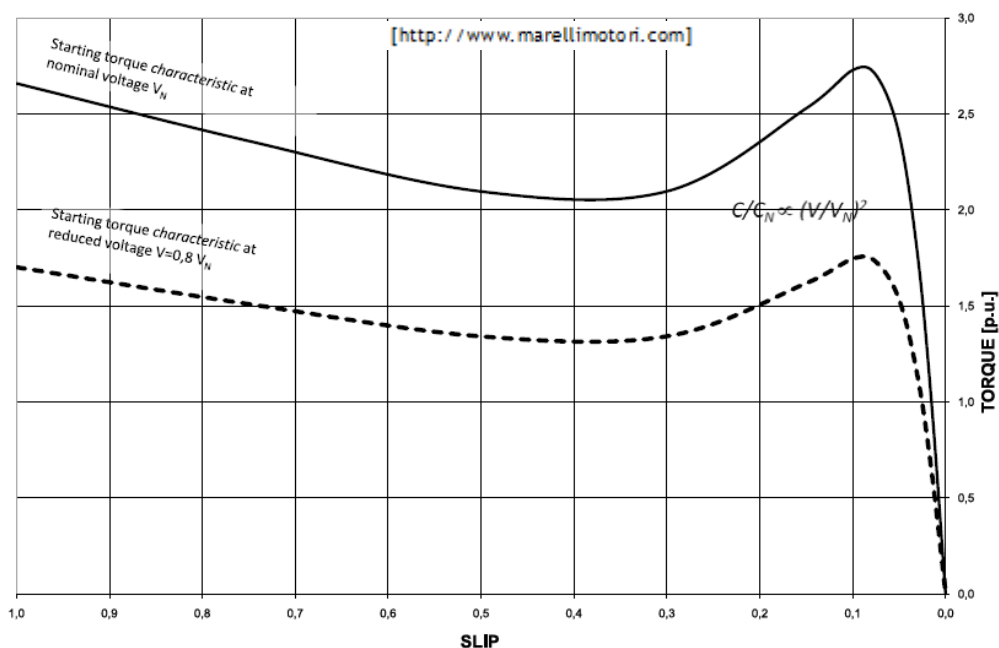

- b. In the figure below, it is possible to distinguish three working regions, or zones, of a three phases induction machine. Considering the different scales for speed (angular speed,  $\omega$ , percent of synchronous speed,  $\% \omega_s$ , slip,  $s$ ) in the horizontal axis, identify these three working zones (1: motor zone; 2: generator zone; 3: braking zone).

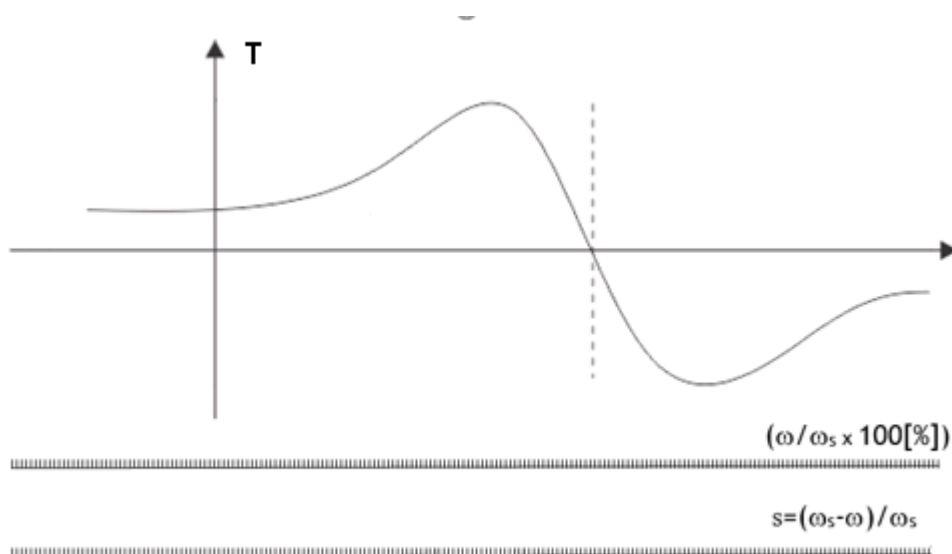

PL 4 - AC Motors - Main components

3. Consider a three-phase power system for an electric motor with a positive, or abc sequence:  $V_a=V_{rms}\angle 0^\circ$ ,  $V_b=V_{rms}\angle -120^\circ$ ,  $V_c=V_{rms}\angle 120^\circ$ . Indicate in the space below the respective: phase and line-to-line voltages, in both the time domain and phasor notation (i.e.  $v_a(t)=V\cos(\omega t+\phi)$ , and  $V_a(j\omega)$ ), considering that  $V_{rms}=230V$ ,  $f=50Hz$ ,  $V_a=V_{L1}$ ,  $V_b=V_{L2}$ ,  $V_c=V_{L3}$ .

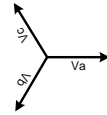

**Phase voltages**

$V_{L1}(j\omega) =$  \_\_\_\_\_       $V_{L2}(j\omega) =$  \_\_\_\_\_       $V_{L3}(j\omega) =$  \_\_\_\_\_  
 $v_{L1}(t) =$  \_\_\_\_\_       $v_{L2}(t) =$  \_\_\_\_\_       $v_{L3}(t) =$  \_\_\_\_\_

**Line, i.e. line-to-line, or compound voltages**

$V_{12}(j\omega) =$  \_\_\_\_\_       $v_{12}(t) =$  \_\_\_\_\_  
 $V_{23}(j\omega) =$  \_\_\_\_\_       $v_{23}(t) =$  \_\_\_\_\_  
 $V_{31}(j\omega) =$  \_\_\_\_\_       $v_{31}(t) =$  \_\_\_\_\_

**Complex AC power, phasor notation:**  $P(j\omega) = \frac{1}{2}V(j\omega) \cdot I^*(j\omega) = V_{rms}(j\omega) \cdot I_{rms}^*(j\omega)$

$P_{average, i.e. real} = |V_{rms}(j\omega)| \cdot |I_{rms}^*(j\omega)| \cdot \cos \varphi = V_{rms} \cdot I_{rms} \cdot \cos \varphi$

$P_{reactive} = |V_{rms}(j\omega)| \cdot |I_{rms}^*(j\omega)| \cdot \sin \varphi = V_{rms} \cdot I_{rms} \cdot \sin \varphi$

$P_{apparent} = |V_{rms}(j\omega)| \cdot |I_{rms}^*(j\omega)| = V_{rms} \cdot I_{rms}$

Power factor:  $\cos \varphi$

**Star (Y) and delta (Δ) connections:**  $V_{phase}$ ,  $V_{line}$ ,  $I_{line}$ ,  $I_z(\text{load})$ ,  $V_z(\text{load})$ :

Delta, Δ:  $I_z = I_{line}/\sqrt{3}$  ;  $V_z = V_{line-to-line} = V_{phase} \cdot \sqrt{3}$

Star, λ:  $I_z = I_{line}$  ;  $V_z = V_{phase}$

Power (real or average) =  $3 \cdot P_z = 3 \cdot V_z \cdot I_z \cdot \cos \varphi$

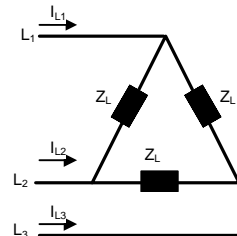

**Calculate the following values, in relation to load ( $Z_L$ ):**

$I_{line\Delta}(Z_L) =$  \_\_\_\_\_

$I_{line\lambda}(Z_L) =$  \_\_\_\_\_

$P_{\Delta}(Z_L) =$  \_\_\_\_\_ [W]

$P_{\lambda}(Z_L) =$  \_\_\_\_\_ [W]

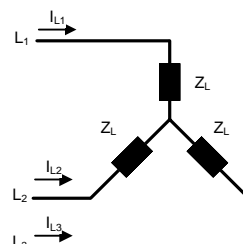

PL 4 - AC Motors - Main components

4. Analyse the information included in the plate identification of a three-phase AC induction motor.

TIPO		M71b4	N°	9716	Is. Cl. F	Prot. IP55	Serv. S1
$\Delta$	$\Upsilon$	Hz	HP	kW	n/l'	A. $\Delta/\Upsilon$	$\Upsilon$
220/380	50	0.5	0.37	1360	2.16 / 1.25	0.69	
240/415	50	0.5	0.37	1370	2.15 / 1.24	0.66	
260/440	60	0.5	0.37	1630	1.83 / 1.06	0.69	
280/480	60	0.5	0.37	1640	1.81 / 1.05	0.66	

- a. Identify from the information of the plate identification the following motor characteristics at 240 $\Delta$ /415 $\Upsilon$  and 50Hz/:

- frequency /voltage /current: \_\_\_\_\_/\_\_\_\_\_/\_\_\_\_\_
- nominal values of: power \_\_\_\_\_torque\_\_\_\_\_speed\_\_\_\_\_
- synchronous speed \_\_\_\_\_
- n° of poles per phase \_\_\_\_\_ n° of pairs of poles per phase \_\_\_\_\_

- b. Represent in the figures below the values for supply voltage and current when the motor is connected in star (a) and delta (b) configurations:

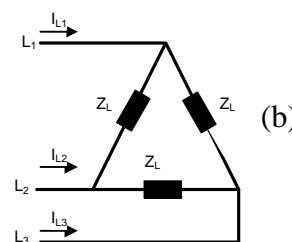
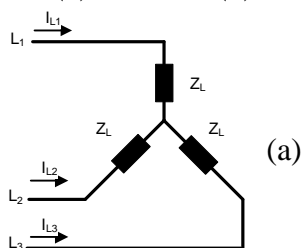

- c. Considering  $f = 50$  Hz, calculate:  
 $P_{active}$  [W] \_\_\_\_\_  $P_{reactive}$  [VAR] \_\_\_\_\_  $P_{apparent}$  [VA] \_\_\_\_\_
- d. Estimate the efficiency of the motor and compare the value with an equivalent motor (i.e. M71B4 da Carpanelli, in the available pdf documents:  $\eta_{motor}$  \_\_\_\_\_)  
 $\eta_{motor} =$  \_\_\_\_\_
- e. What motor connection ( $\Delta$  or  $\Upsilon$ ) to use if the motor is to be powered directly (DOL) from the AI laboratory electric installation? \_\_\_\_\_